

AU6210HD Datasheet

USB Host MP3 Decoder SOC

Rev0.1

DISCLAIMER

All information and data contained in this document are without any commitment, are not to be considered as an offer for conclusion of a contract, nor shall they be construed as to create any liability. Any new issue of this document invalidates previous issues. Product availability and delivery are exclusively subject to our respective order confirmation form; the same applies to orders based on delivered development samples delivered. By this publication, Shanghai Mountain View Silicon Technology Co., Ltd. (“MVSILICON”) does not assume responsibility for patent infringements or other rights of third parties that may result from its use.

No part of this publication may be reproduced, photocopied, stored in a retrieval system, or translated in any form or by any means, electronic, mechanical, manual, optical, or otherwise, without the prior written permission of Shanghai Mountain View Silicon Technology Co., Ltd.

Shanghai Mountain View Silicon Technology Co., Ltd. assumes no responsibility for any errors contained herein.

Revision History

Date	Revision	Description
	V0.1	Initial

Contents

Revision History	iii
Contents	iv
Figures.....	v
Tables	vi
1. Overview	1
1.1 Features	1
1.2 Chip Architecture	2
2. System Application	3
3. Pin Description.....	4
3.1 Pin Description.....	4
4. Package	5
4.1 Package Diagram	5
4.2 Package Dimension Parameter	6
5. Electrical Specification	7
5.1 Absolute Maximum Ratings (Note 1).....	7
5.2 Recommended Operating Conditions	7
5.3 Electrical Characteristics	7
5.4 Audio Performance	7

Figures

Figure 1 AU6210HD Functional Block Diagram.....	2
Figure 2 MP3 Audio System.....	3
Figure 3 Package Diagram (SOP28 / TOP View)	5
Figure 4 SOP28 Package Dimension Parameter.....	6

Tables

Table 1 Pin Description	4
Table 2 Absolute Maximum Ratings	7
Table 3 Recommended Operating Conditions	7
Table 4 Electrical Characteristics	7
Table 5 MP3 Audio Performance	7
Table 6 Line in Audio Performance.....	7
Table 7 FM Audio Performance	8

1. Overview

A highly integrated SOC for MP3 player, AU6210HD integrates MCU, FM receiver, MP3 decoder, OTG, SD/MMC card controller, SARADC, Audio DAC, segment LED display driver, RTC and key tone generator in a single chip. AU6210HD is suitable for low end host MP3 player solution with segment LED display.

1.1 Features

- | Enhanced 8051, up to 10 times faster than standard 8051
- | Embedded FM receiver
- | OTG 2.0 full-speed controller
- | SD/MMC card controller
- | Support MP3 decoder
- | Embedded sound equalizer
- | Support FAT16/FAT32 file system
- | Embedded 18-bit Audio CODEC
- | Support auxiliary audio input
- | Embedded SARADC for peripheral controls
- | Embedded NVM to save external EEPROM
- | Support led display during battery charging.
- | Embedded RTC.
- | Embedded key tone generator.
- | Support segment LED display.
- | GPIO for various purposes
- | Embedded LDO
- | Embedded Power-on-Reset
- | Embedded 32KB OTP for program code storage

1.2 Chip Architecture

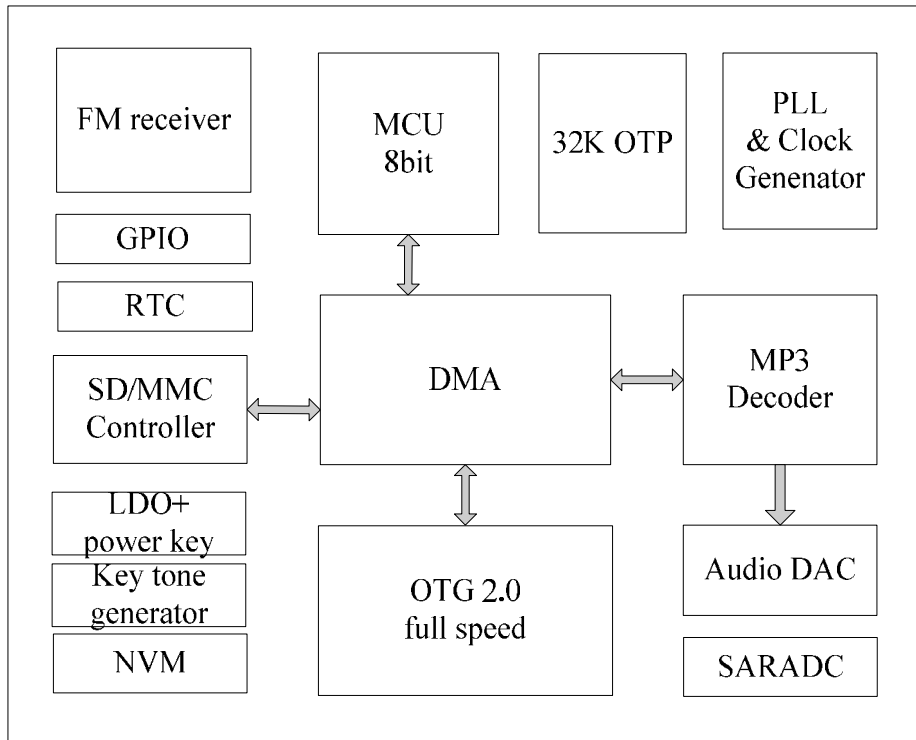

Figure 1 AU6210HD Functional Block Diagram

2. System Application

I MP3 audio system

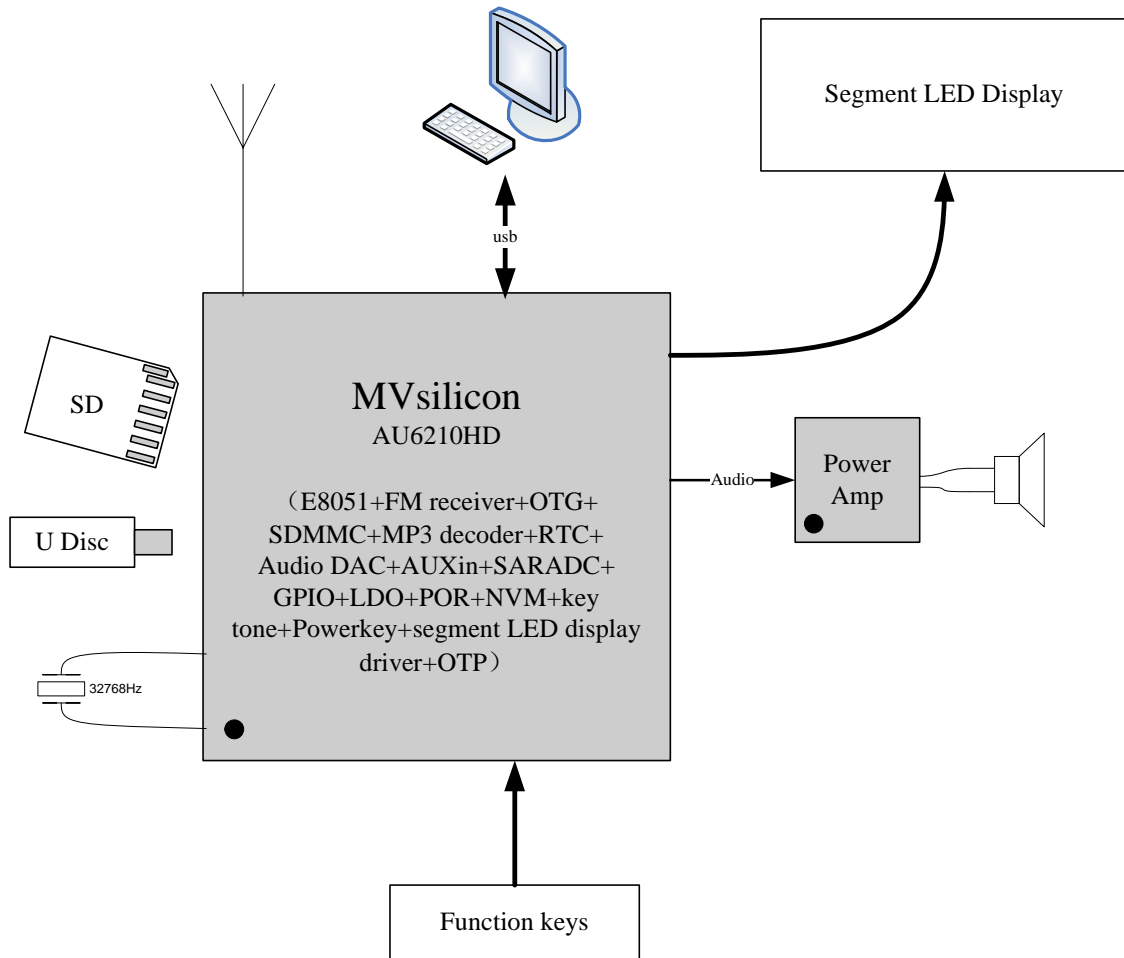

Figure 2 MP3 Audio System

3. Pin Description

AU6210HD is a CMOS device. Floating level on input signals causes unstable device operation and abnormal current consumption. Pull-up or Pull-down resistors should be used appropriately for input or bidirectional pins.

Notation	Description
I	Input
O	Output
I/O	Bidirectional
PWR	Power
GND	Ground

3.1 Pin Description

Table 1 Pin Description

Pin name	Pin #	Type	Description
USB interface pins			
USB_DP	18	I/O	USB Function D+ bus
USB_DM	19	I/O	USB Function D- bus
Audio CODEC interface pins			
DAC_R	6	AO	audio right channel output
DAC_L	7	AO	audio left channel output
DACVMID	5	AI	Internal voltage reference
DAC_LINER/ DAC_LINEL	9	AI	Audio aux right in/ Audio aux left in
GPIO/MCU IO pins			
GPIO_A[5:3]	22:20	I/O	GPIO PORT, bank A
GPIO_A[2:0]	17:15	I/O	GPIO PORT, bank A
GPIO_B[6]	24	I/O	GPIO PORT, bank B
GPIO_D[7]	1	I/O	GPIO PORT, bank D
GPIO_D[6:3]	28:25	I/O	GPIO PORT, bank D
CLK pins			
XIN	10	I	32.768KHz Crystal oscillator input for PLL
XOUT	11	O	32.768KHz Crystal oscillator output for PLL
FM pins			
RFI	3	AI	FM Antenna input
Power/Ground pins			
FMVSS	2	GND	Ground for FM
DVSS	23	GND	ground for digital
LDOIN	13	PWR	LDO power in
LDO330	12	PWR	LDO 3.3V out

DACVDD	8	PWR	power for DAC
DACVSS	4	PWR	Ground for DAC
MISC pins			
POWER_KEY	15	I	Power Key

4. Package

4.1 Package Diagram

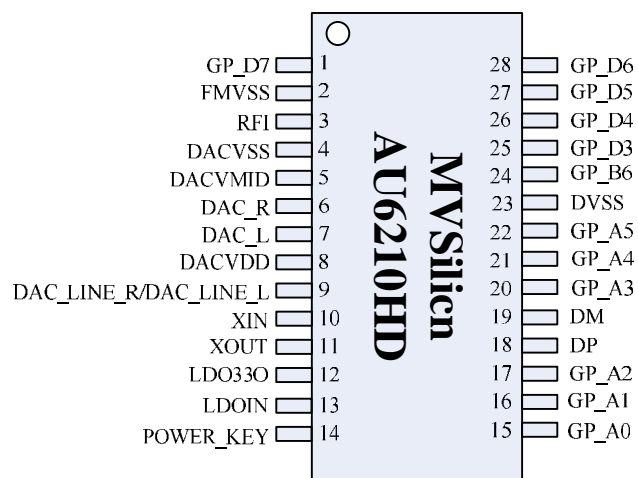

Figure 3 Package Diagram (SOP28 / TOP View)

4.2 Package Dimension Parameter

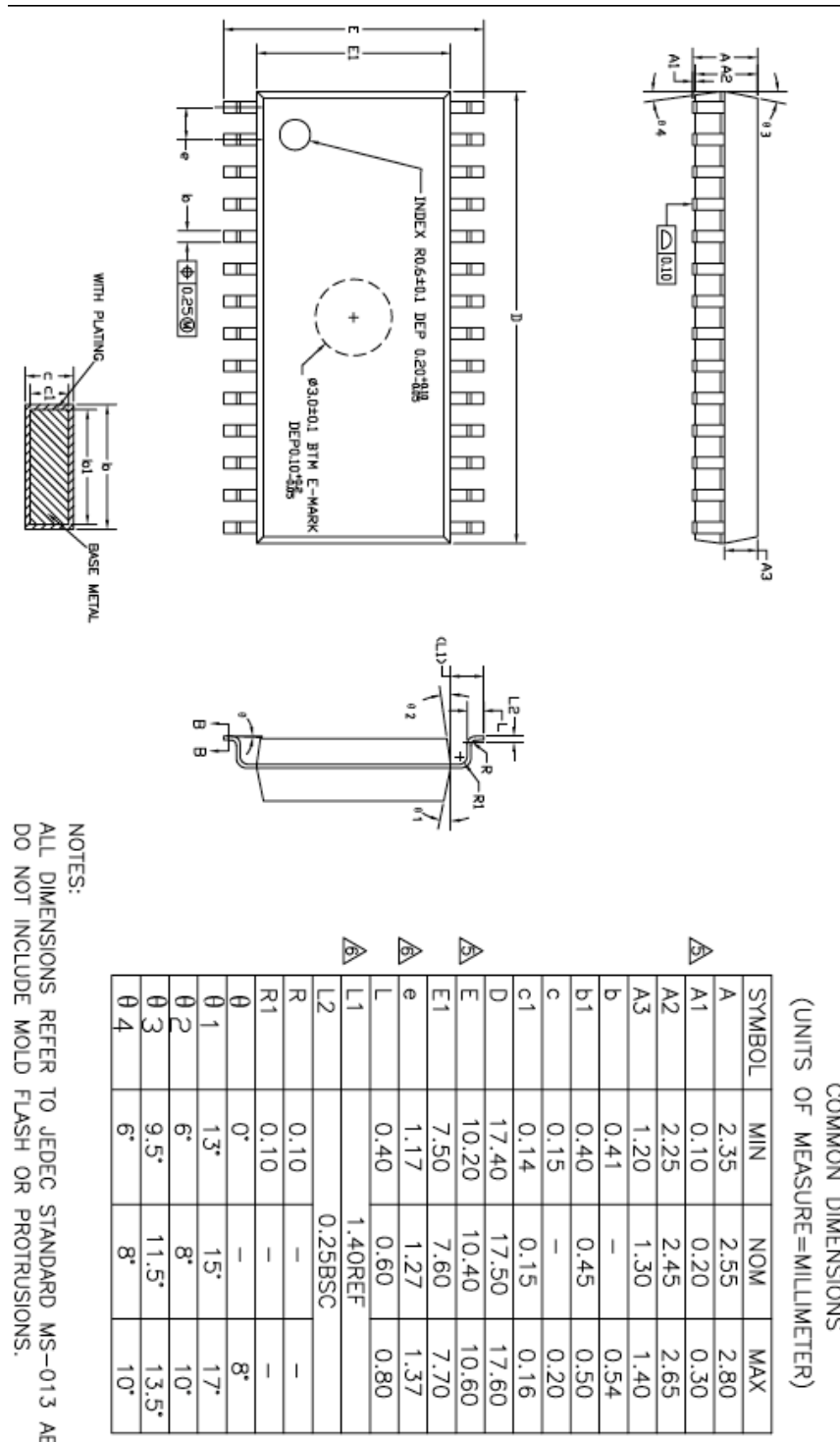

Figure 4 SOP28 Package Dimension Parameter

5. Electrical Specification

5.1 Absolute Maximum Ratings (Note 1)

Table 2 Absolute Maximum Ratings

Parameter	Symbol	Rating	Unit
Storage Temperature	TEMP_STG	-65 to 150	C

5.2 Recommended Operating Conditions

Table 3 Recommended Operating Conditions

Parameter	Symbol	Min	Typ	Max	Unit
Power Supply Voltage (LDO)	VCC_LDO	3.35		5	V
IO Input Voltage	VIN	0		3.6	V
Operating Free Air Temperature	TEMP_OPR	-20		75	C

5.3 Electrical Characteristics

Table 4 Electrical Characteristics

Symbol	Parameter	Condition	Min	Typ	Max	Unit
V _{IH}	Input High Voltage		1.6		3.6	V
V _{IL}	Input Low Voltage		-0.3		1.4	V
V _{OH}	Output high voltage	@IOH=2mA	3.0			V
V _{OL}	Output low voltage	@IOL=2mA			0.3	V
I _L	Input leakage current		-10		10	uA
P _{PLAY} current	Current consumption when playing	Playing mode		20		mA
RTC current	Current consumption for RTC & NVM			13		uA

5.4 Audio Performance

Table 5 MP3 Audio Performance

Characteristics	Min	Typ	Max	Unit
Frequency Response 20Hz ~ 18KHz		<0.5%		DB
THD+N(1KHz out = 950mv rms)		0.1%		%
S/N (1KHz out = 950mv rms)		75		DB
L/R Channel Difference		0		DB
L/R Channel Separation		75		DB
DAC WITH 32OHM Loading OUT POWER		>20		MW

Table 6 Line in Audio Performance

Characteristics	Min	Typ	Max	Unit
Frequency Response 20Hz ~ 20KHz		<0.5%		DB



THD+N(1KHz out = 950mv rms)		0.05%		%
S/N (1KHz out = 950mv rms)		75		DB
L/R Channel Difference		0		DB
L/R Channel Separation		75		DB

Table 7 FM Audio Performance

Characteristics	Min	Typ	Max	Unit
RX_Sensitivity (Mono)		<2		uV
RX_S/N (Stereo)		64		DB
RX_S/N (Mono)		60		DB
L/R Channel Difference (Mono)		0		DB
L/R Channel Separation (Stereo)		45		DB
RX_THD (Mono)		0.1%		%

Note:

1. “Absolute Maximum Ratings” are those values beyond which the safety of the device cannot be guaranteed. They are not meant to imply that the device should be operated at these limits.

Contact Information

Shanghai Mountain View Silicon Technology Co Ltd

Shanghai Headquarter:

Room 602, Building Y2, No.112 Liangxiu Road, Pudong,
Shanghai, P.R. China

Zip code: 201203

Tel: 86-21-68549851/68549853/68549857/61630160

Fax: 86-21-61630162

Shenzhen Sales & Technical Support Office:

Suite 6A Olympic Plaza, Shangbao Road, Futian District,
Shenzhen, Guangdong, P.R. China

Zip code: 518034

Tel: 86-755-83522955

Fax: 86-755-83522957

Email: support@mvsilicon.com

Website: <http://www.mvsilicon.com>